

TM 11-6665-224-20P

TECHNICAL MANUAL

ORGANIZATIONAL MAINTENANCE REPAIR PARTS AND SPECIAL TOOLS LISTS
FOR

RADIAC SET AN/PDR-27P
(NSN 6665-00-975-7222)

HEADQUARTERS, DEPARTMENT OF THE ARMY
4 JANUARY 1978

TECHNICAL MANUAL }
 No. 11-6665-224-20P }

HEADQUARTERS
 DEPARTMENT OF THE ARMY
 WASHINGTON, DC, 4 January 1978

**ORGANIZATIONAL MAINTENANCE REPAIR PARTS AND SPECIAL TOOLS LISTS
 FOR**

**RADIAC SET AN/PDR-27P
 (NSN 6665-00-975-7222)**

Current as of 24 September 1977

REPORTING OF ERRORS

You can improve this manual by recommending improvements using DA Form 2028-2 (Test) located in the back of the manual. Simply tear out the self-addressed form, fill it out as shown on the sample, fold it where shown, and drop it in the mail.

If there are no blank DA Form 2028-2 (Test) in the back of your manual, use the standard DA Form 2028 (Recommended Changes to Publications and Blank Forms) and forward to the Commander, US Army Electronics Command, ATTN: DRSEL-MA-Q Fort Monmouth, NJ 07703.

In either case a reply will be furnished direct to you.

TABLE OF CONTENTS

		Page	Illus Figure
SECTION I.	Introduction	1	
II.	Repair parts list	5	
GROUP 00	Radiac Set AN/PDR-27P	5	1
01	Radiac Meter IM-177/PDR-27P	7	2,3
	0101 Printed circuit board (A3) (No parts authorized)		
02	Radiac Detector DT-196/PDR-27J (No parts authorized)		
03	Headset H-43 B/U (See TM 11-5965-247-12P for parts)		
04	Case, Carrying CY-2312/PDR-27L (No parts authorized)		
SECTION III.	Special tools list (Not applicable)		
IV.	National stock number and part number index	10	

SECTION I INTRODUCTION

1. Scope

This manual lists spares and repair parts; special tools; special test, measurement, and diagnostic equipment (TMDE), and other special support equipment required for performance of organizational maintenance of the AN/PDR-27P. It authorizes the requisitioning and issue of spares and repair parts as indicated by the source and maintenance codes.

2. General

This Repair Parts and Special Tools List is divided into the following sections:

a. Section II. Repair Parts List. A list of spares and repair parts authorized for use in the performance of maintenance. The list also includes parts which must be removed for replacement of the authorized parts. Parts lists are composed of functional groups in numeric sequence, with the parts in each group listed in figure and item number sequence.

b. Section III. Special Tools List. Not applicable.

c. Section IV. National Stock Number and Part Number Index. A list, in National item identification number (NIIN) sequence, of all National stock numbers (NSN) appearing in the listings, followed by a list, in alphameric sequence, of all part numbers appearing in the listings. National stock numbers and part numbers are cross-referenced to each illustration figure and item number appearance.

3. Explanation of Columns

a. Illustration. This column is divided as follows:

(1) *Figure number.* Indicates the figure number of the illustration on which the item is shown.

(2) *Item number.* The number used to identify item called out in the illustration.

b. Source, Maintenance, and Recoverability (SMR) Codes.

(1) *Source code.* Source codes indicate the manner of acquiring support items for maintenance, repair, or overhaul of end items. Source codes are entered in the first and second positions of the Uniform SMR Code format as follows:

<i>Code</i>	<i>Definition</i>
PA	Item procured and stocked for anticipated or known usage.

NOTE

Cannibalization or salvage may be used as a source of supply for any items source

coded above except those coded XA and aircraft support items as restricted by AR 700-42.

(2) *Maintenance code.* Maintenance codes are assigned to indicate the levels of maintenance authorized to USE and REPAIR support items. The maintenance codes are entered in the third and fourth positions of the Uniform SMR Code format as follows:

(a) The maintenance code entered in the third position will indicate the lowest maintenance level authorized to remove, replace, and use the support item. The maintenance code entered in the third position will indicate one of the following levels of maintenance:

<i>Code</i>	<i>Application/Explanation</i>
O	Support item is removed, replaced, used at the organizational level.

(b) The maintenance code entered in the fourth position indicates whether the item is to be repaired and identifies the lowest maintenance level with the capability to perform complete repair (i.e., all authorized maintenance functions). This position will contain one of the following maintenance codes:

<i>Code</i>	<i>Application/Explanation</i>
H	The lowest maintenance level capable of complete repair of the support item is the general support level.
Z	Nonreparable. No repair is authorized.

(3) *Recoverability code.* Recoverability codes are assigned to support items to indicate the disposition action on unserviceable items. The recoverability code is entered in the fifth position of the Uniform SMR Code format as follows:

<i>Recoverability codes</i>	<i>Definition</i>
Z	Nonreparable item. When unserviceable, condemn and dispose at the level indicated in position 3.
D	Reparable item. When beyond lower level repair capability, return to depot. Condemnation and disposal not authorized below depot level.

c. National Stock Number. Indicates the National stock number assigned to the item and will be used for requisitioning purposes,

d. Part Number. Indicates the primary number used by the manufacturer (individual, company,

firm, corporation, or Government activity), which controls the design and characteristics of the item by means of its engineering drawings, specifications, standards, and inspection requirements to identify an item or range of items.

NOTE

When a stock numbered item is requisitioned, the repair part received may have a different part number than the part being replaced.

e. Federal Supply Code for Manufacturer (FSCM). The FSCM is a 5-digit numeric code listed in SB 708-42 which is used to identify the manufacturer, distributor, or Government agency, etc.

J. Description. Indicates the Federal item name and, if required, a minimum description to identify the item.

g. Unit of Measure (U/M). Indicates the standard of the basic quantity of the listed item as used in performing the actual maintenance function. This measure is expressed by a two-character alphabetical abbreviation (e.g., ea, in, pr, etc). When the unit of measure differs from the unit of issue, the lowest unit of issue that will satisfy the required units of measure will be requisitioned.

h. Quantity Incorporated in Unit. Indicates the quantity of the item used in the breakout shown on the illustration figure, which is prepared for a functional group, subfunctional group, or an assembly.

4. Special Information

a. The following publications pertain to the AN/PDR-27P and its components:

TM 11-5965-247-12P, Headset, Electrical H-43B/U
TM 11-6665-224-15, Radiac Set AN/PDR-27P

b. The illustrations in this manual are identical to those published in TM 11-6665-224-40P. Only

those parts assigned the third position SMR maintenance code "C" or "O" are listed in the tabular listing; therefore, there may be a break in the item number sequence. Only illustrations containing organizational authorized items appear in this manual.

5. How to Locate Repair Parts

a. When National stock number or part number is unknown.

(1) *First.* Using the table of contents, determine the functional group within which the item belongs. This is necessary since illustrations are prepared for functional groups and listings are divided into the same groups.

(2) *Second.* Find the illustration covering the functional group to which the item belongs.

(3) *Third.* Identify the item on the illustration and note the illustration figure and item number of the item.

(4) *Fourth.* Using the Repair Parts Listing, find the figure and item number noted on the illustration.

b. When National stock number or part number is known.

(1) *First.* Using the Index of National Stock Numbers and Part Numbers, find the pertinent National stock number or part number. This index is in NIIN sequence followed by a list of part numbers in alphameric sequence, cross-referenced to the illustration figure number and item number.

(2) *Second.* After finding the figure and item number, locate the figure and item number in the repair parts list.

6. Abbreviations

Not applicable.

(Next printed page is 4.)

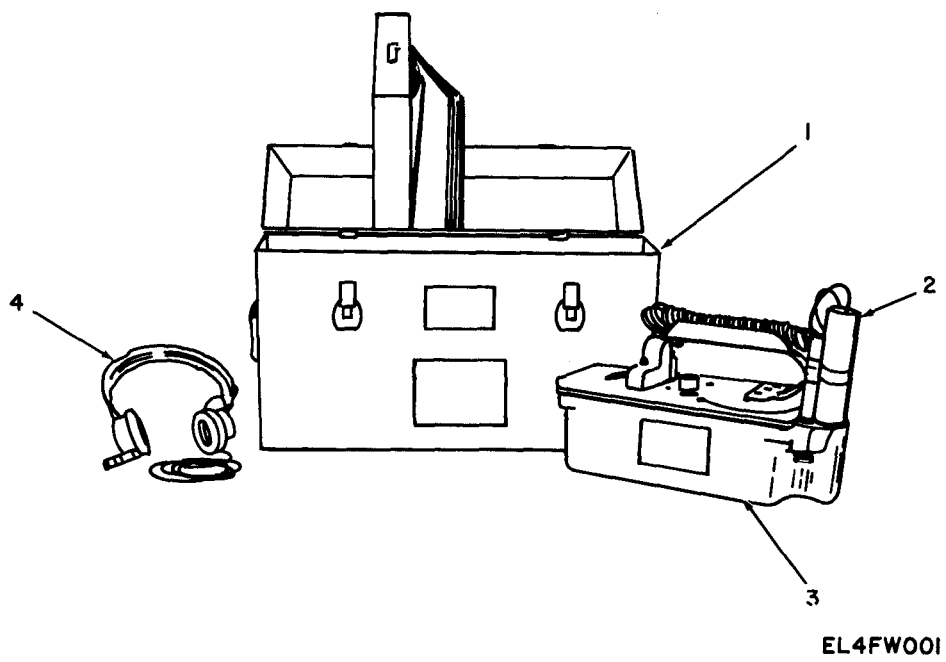
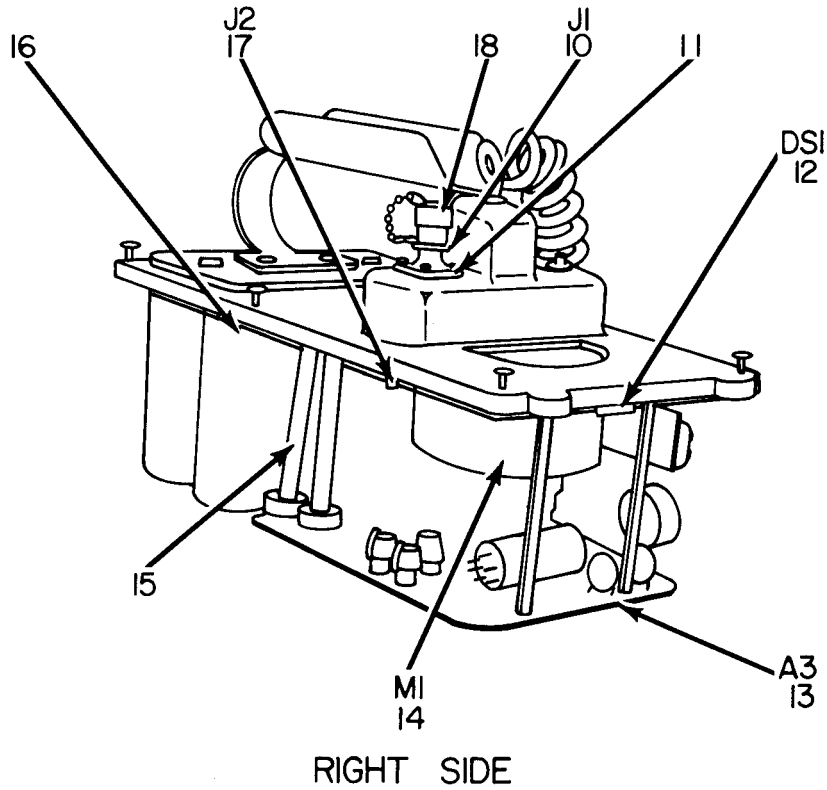
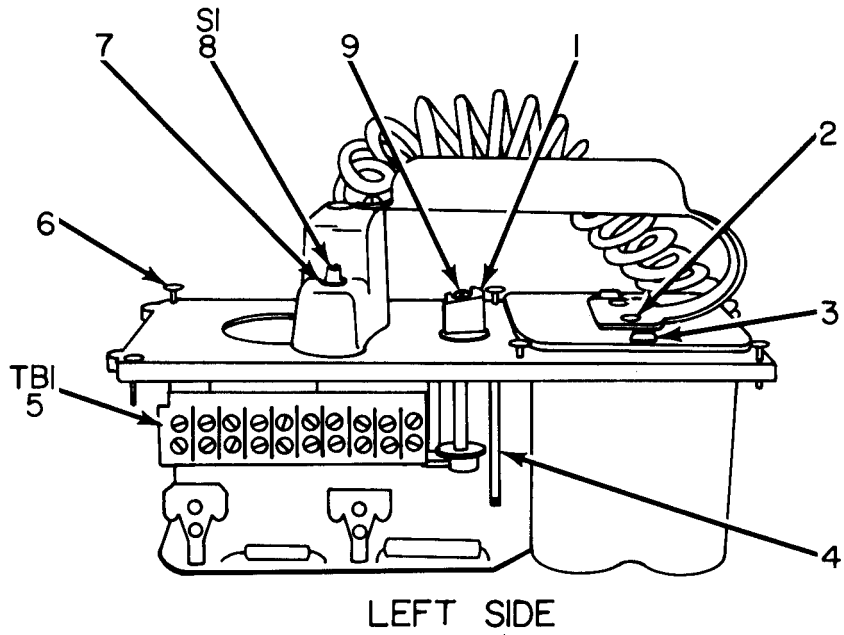

Figure 1. Radiac Set AN/PDR-27P.

SECTION IV

(1)	(2)	(3)	(4)	(5)	(6)	(7)	(8)
ILLUSTRATION					DESCRIPTION	QTY	
(a)	(b)	NATIONAL	PART			INC	
FIG	ITEM	SMR	STOCK	PART		IN	
NO.	NO.	CODE	NUMBER	NUMBER	FSCM	USABLE O U\M	UNIT
GROUP 00 RADIAC SET AN/PDR-27P							
1	1	PAOZZ	6665-00-618-9945	CY-2312/PDR-27L	80058	CASE, CARRYING	EA 1
1	3	PAOHD	6625-00-078-4179	IM177PDR27P	80058	RADIAC METER	EA 1



EL4FW002

Figure 2. Radiac Meter IM-177/PDR-27P.

SECTION IV

(1)	(2)	(3)	(4)	(5)	(6)	(7)	(8)
ILLUSTRATION							QTY
(a)	(b)	NATIONAL			DESCRIPTION		INC
FIG	ITEM	SMR	STOCK	PART			IN
NO.	NO.	CODE	NUMBER	NUMBER	FSCM	USABLE ON COD U\M	UNIT
GROUP 01 RADIAC METER IM-177/PDR-27P							
2	1	PAOZZ	5355-00-656-1275	3651527	94988	KNOB	EA 1
2	2	PAOZZ	5305-00-685-1799	11383	94988	SCREW,EXT RLV BODY	EA 2
2	3	PAOZZ	5305-00-947-7033	11364	94988	SCREW,SEAL	EA 2
2	4	PAOZZ	6665-00-675-9415	3061503	94988	PLATE,DETENT	EA 1
2	6	PAOZZ	5305-00-685-1800	11414	94988	SCREW,EXT RLV BODY	EA 7
2	7	PAOZZ	5930-00-950-4541	11365	97539	NUT,SEAL	EA 1
2	9	PAOZZ	5305-00-281-3118	3201505	94988	SCREW,SET	EA 2
2	11	PAOZZ	5355-00-656-1275	902-1	86579	GASKET	EA 1
2	16	PAOZZ	5330-00-542-1752	1320048	70064	GASKET	EA 1

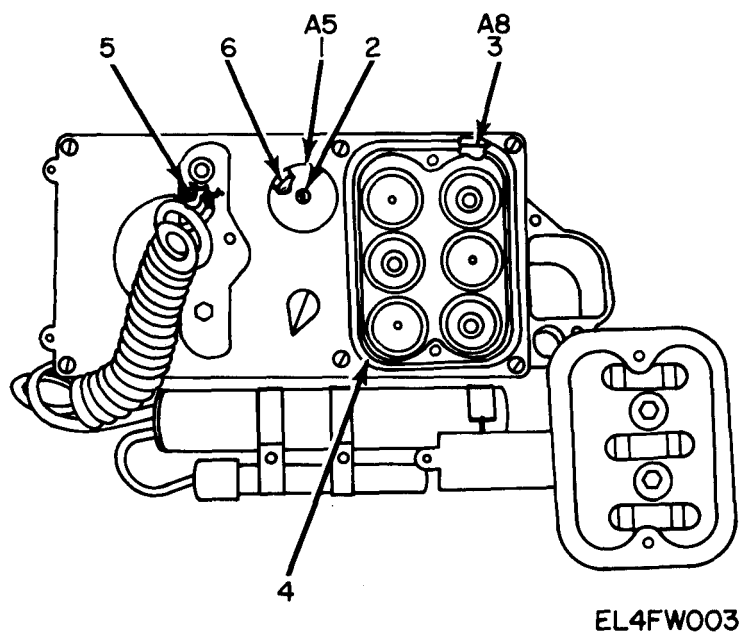

Figure 3. Radiac Meter IM-177/PDR-27P.

SECTION IV

(1)	(2)	(3)	(4)	(5)	(6)	(7)	(8)	
ILLUSTRATION								
(a)	(b)	NATIONAL			DESCRIPTION		QTY	
FIG	ITEM	SMR	STOCK	PART			INC	
NO.	NO.	CODE	NUMBER	NUMBER	FSCM	USABLE ON CODE	U\M	UNIT
3	1	PAOZZ	6665-00-675-9401	11319	94988	CAP, ALUMINUM	EA	1
3	2	PAOZZ	5305-00-947-7033	11364	94988	SCREW, SEAL	EA	1
3	4	PAOZZ	5330-00-542-1753	521-1320047	15249	GASKET	EA	1
3	6	PAOZZ	5355-00-656-1275	902-1	86579	GASKET	EA	1

NATIONAL STOCK NUMBER AND PART NUMBER INDEX

NOTE: LATEST NATIONAL STOCK NUMBER ASSIGNMENTS ARE INCLUDED AT END OF INDEX

STOCK NUMBER	FIGURE NO.	ITEM NO.	STOCK NUMBER	FIGURE NO.	ITEM NO.
6665-00-078-4179	1	3	6665-00-675-9415	2	4
5305-00-281-3118	2	9	5305-00-685-1799	2	4
5330-00-542-1752	2	16	5305-00-685-1800	2	6
5330-00-542-1753	3	4	5305-00-947-7033	2	3
5355-00-656-1275	2	1	5305-00-947-7033	3	2
6665-00-675-9401	3	1	5930-00-950-4541	2	7

PART NUMBER	FSCM	FIG NO	ITEM NO	PART NUMBER	FSCM	FIG NO	ITEM NO
CY-2312/PDR-27L	80058	1	1	1320048	70064	2	16
IM177PDR27P	80058	1	3	3061503	94988	2	4
11319	94988	3	1	3201505	94988	2	9
11364	94988	2	3	3651527	94988	2	1
11364	94988	3	2	521-1320047	15249	3	4
11365	97539	2	7	902-1	86579	2	11
11383	94988	2	2	902-1	86579	3	6
11414	94988	2	6				

LATEST NATIONAL STOCK NUMBER ASSIGNMENTS

STOCK NUMBER	FIG. NO.	ITEM NO.
6665-00-618-9945	1	1
5355-00-656-1275	2	11
5355-00-656-1275	3	6

By Order of the Secretary of the Army:

BERNARD W. ROGERS
General, United States Army
Chief of Staff

Official:

J. C. PENNINGTON
Brigadier General, United States Army
The Adjutant General

Distribution:

To be distributed in accordance with DA Form 12-50, Section I, Organizational Literature requirements for AN/PDR-27.

RECOMMENDED CHANGES TO EQUIPMENT TECHNICAL MANUALS



SOMETHING WRONG WITH THIS MANUAL?

THEN... JOT DOWN THE DOPE ABOUT IT ON THIS FORM, TEAR IT OUT, FOLD IT AND DROP IT IN THE MAIL!

FROM: (YOUR UNIT'S COMPLETE ADDRESS)

Commander
Stateside Army Depot
ATTN: AMSTA-US
Stateside, N.J. 07703

DATE 10 July 1975

PUBLICATION NUMBER

TM 11-5840-340-12

DATE

23 Jan 74

TITLE

Radar Set AN/P-3-76

BE EXACT... PIN-POINT WHERE IT IS

IN THIS SPACE TELL WHAT IS WRONG AND WHAT SHOULD BE DONE ABOUT IT:

PAGE NO.	PARA-GRAPH	FIGURE NO.	TABLE NO.
----------	------------	------------	-----------

2-25	2-28		
3-10	3-3		3-1
5-6	5-8		

FO3

Recommend that the installation antenna alignment procedure be changed throughout to specify a 2° IFF antenna lag rather than 1°.

REASON: Experience has shown that with only a 1° lag, the antenna servo system is too sensitive to wind gusting in excess of 25 knots, and has a tendency to rapidly accelerate and decelerate as it hunts, causing strain to the drive train. Hunting is minimized by adjusting the lag to 2° without degradation of operation.

Item 5, Function column. Change "2 db" to "3db."

REASON: The adjustment procedure for the TRANS POWER FAULT indicator calls for a 3 db (500 watts) adjustment to light the TRANS POWER FAULT indicator.

Add new step f.1 to read, "Replace cover plate removed in step e.1, above."

REASON: To replace the cover plate.

Zone C 3. On J1-2, change "+24 VDC to "+5 VDC."

REASON: This is the output line of the 5 VDC power supply. + 24 VDC is the input voltage.

TYPED NAME, GRADE OR TITLE, AND TELEPHONE NUMBER

SSG I. M. DeSpirito 999-1776

SIGN HERE:

SSG I. M. DeSpirito

DA FORM 2028-2 (TEST)
1 AUG 74

P.S.--IF YOUR OUTFIT WANTS TO KNOW ABOUT YOUR MANUAL "FIND," MAKE A CARBON COPY OF THIS AND GIVE IT TO YOUR HEADQUARTERS.

HISA 1686-75

TEAR ALONG DOTTED LINE

RECOMMENDED CHANGES TO EQUIPMENT TECHNICAL MANUALS



SOMETHING WRONG WITH THIS MANUAL?

THEN... JOT DOWN THE DOPE ABOUT IT ON THIS FORM, TEAR IT OUT, FOLD IT AND DROP IT IN THE MAIL!

FROM: (YOUR UNIT'S COMPLETE ADDRESS)

DATE

PUBLICATION NUMBER

DATE

TITLE

T14 11-6665-224-207

3 Jan 78

BE EXACT... PIN-POINT WHERE IT IS

IN THIS SPACE TELL WHAT IS WRONG AND WHAT SHOULD BE DONE ABOUT IT:

PAGE NO.

PARA-GRAPH

FIGURE NO.

TABLE NO.

TEAR ALONG DOTTED LINE

TYPED NAME, GRADE OR TITLE, AND TELEPHONE NUMBER

SIGN HERE:

DA FORM 2028-2 (TEST)
1 AUG 74

P.S.--IF YOUR OUTFIT WANTS TO KNOW ABOUT YOUR MANUAL "FIND," MAKE A CARBON COPY OF THIS AND GIVE IT TO YOUR HEADQUARTERS.

FILL IN YOUR
UNIT'S ADDRESS

FOLD BACK

DEPARTMENT OF THE ARMY

OFFICIAL BUSINESS

PENALTY FOR PRIVATE USE, \$300

POSTAGE AND FEES PAID
DEPARTMENT OF THE ARMY
DOD-314



Commander
US Army Electronics Command
ATTN: DRSEL-MA-Q
Fort Monmouth, New Jersey 07703

FOLD BACK

TEAR ALONG DOTTED LINE

REVERSE OF DA FORM 2028-2 (TEST)

THE METRIC SYSTEM AND EQUIVALENTS

WEIGHT MEASURE

1 Centimeter = 10 Millimeters = 0.01 Meters = 0.3937 Inches
 1 Meter = 100 Centimeters = 1000 Millimeters = 39.37 Inches
 1 Kilometer = 1000 Meters = 0.621 Miles

WEIGHTS

1 Gram = 0.001 Kilograms = 1000 Milligrams = 0.035 Ounces
 1 Kilogram = 1000 Grams = 2.2 lb.
 1 Metric Ton = 1000 Kilograms = 1 Megagram = 1.1 Short Tons

LIQUID MEASURE

1 Milliliter = 0.001 Liters = 0.0338 Fluid Ounces
 1 Liter = 1000 Milliliters = 33.82 Fluid Ounces

SQUARE MEASURE

1 Sq. Centimeter = 100 Sq. Millimeters = 0.155 Sq. Inches
 1 Sq. Meter = 10,000 Sq. Centimeters = 10.76 Sq. Feet
 1 Sq. Kilometer = 1,000,000 Sq. Meters = 0.386 Sq. Miles

CUBIC MEASURE

1 Cu. Centimeter = 1000 Cu. Millimeters = 0.06 Cu. Inches
 1 Cu. Meter = 1,000,000 Cu. Centimeters = 35.31 Cu. Feet

TEMPERATURE

$5/9(^{\circ}\text{F} - 32) = ^{\circ}\text{C}$
 212° Fahrenheit is equivalent to 100° Celsius
 90° Fahrenheit is equivalent to 32.2° Celsius
 32° Fahrenheit is equivalent to 0° Celsius
 $9/5^{\circ}\text{C} + 32 = ^{\circ}\text{F}$

APPROXIMATE CONVERSION FACTORS

TO CHANGE	TO	MULTIPLY BY
Inches	Centimeters	2.540
Feet	Meters	0.305
Yards	Meters	0.914
Miles	Kilometers	1.609
Square Inches	Square Centimeters	6.451
Square Feet	Square Meters	0.093
Square Yards	Square Meters	0.836
Square Miles	Square Kilometers	2.590
Acres	Square Hectometers	0.405
Cubic Feet	Cubic Meters	0.028
Cubic Yards	Cubic Meters	0.765
Fluid Ounces	Milliliters	29.573
its	Liters	0.473
arts	Liters	0.946
allons	Liters	3.785
Ounces	Grams	28.349
Pounds	Kilograms	0.454
Short Tons	Metric Tons	0.907
Pound-Feet	Newton-Meters	1.356
Pounds per Square Inch	Kilopascals	6.895
Miles per Gallon	Kilometers per Liter	0.425
Miles per Hour	Kilometers per Hour	1.609

TO CHANGE	TO	MULTIPLY BY
Centimeters	Inches	0.394
Meters	Feet	3.280
Meters	Yards	1.094
Kilometers	Miles	0.621
Square Centimeters	Square Inches	0.155
Square Meters	Square Feet	10.764
Square Meters	Square Yards	1.196
Square Kilometers	Square Miles	0.386
Square Hectometers	Acres	2.471
Cubic Meters	Cubic Feet	35.315
Cubic Meters	Cubic Yards	1.308
Milliliters	Fluid Ounces	0.034
Liters	Pints	2.113
Liters	Quarts	1.057
ers	Gallons	0.264
ms	Ounces	0.035
ograms	Pounds	2.205
Metric Tons	Short Tons	1.102
Newton-Meters	Pounds-Feet	0.738
Kilopascals	Pounds per Square Inch	0.145
ometers per Liter	Miles per Gallon	2.354
ometers per Hour	Miles per Hour	0.621

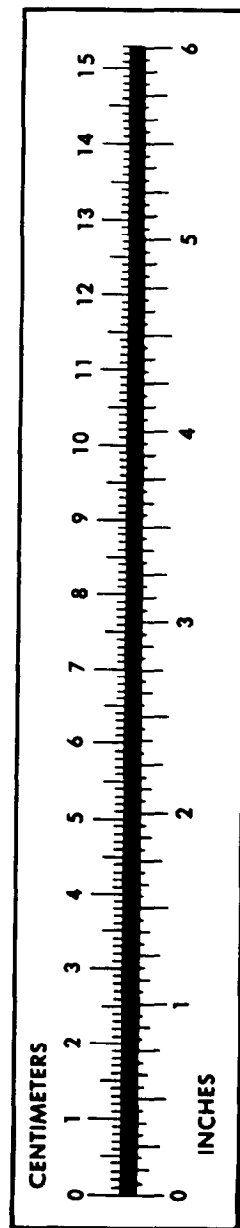

PIN: 019512-000